



Human Machine Interfaces  
efficient XGT Panel

# eXP Series



## Effective Control and Monitoring Solution Cost-Efficient eXP!

- ☑ Simple Design
- ☑ 7" and 10.2" wide-screen sizes TFT color LCD
- ☑ Wide variety of communication interfaces
  - 3-channel serial communication
  - Ethernet
- ☑ Large memory for drawing (64MB)
- ☑ RTC function (maintained by battery)
- ☑ Convenient downloading/uploading of drawings via USB port in the front



- TFT LCD-applied wide type
- LED Backlight adopted for enhanced contrast ratio and low-power
- PLC Ladder monitoring function: Only XGK/XBC supports\*
- Web Server\* / Data Server\* / Path-Through Function\*
- Remote Viewer Function\*
- Screen editor : XP-Builder

\* Functions that support only the TTA model



## Specifications

Item	eXP40-TTE/DC	eXP40-TTA/DC	eXP60-TTA/DC
Display Type	TFT color LCD		
Display Size	17.7cm (7 inch)		25.9cm (10.2 inch)
Resolution	800 x 480 (WVGA)		
Color	65,536 colors		
Display Angle	Left/Right: 60 deg. Up: 40 deg. Down: 60 deg.		Left/Right: 55 deg. Up: 35 deg. Down: 55 deg.
Backlight	LED mode, Auto On/Off		
Backlight Capacity	20,000 hr		
Brightness	230 cd/m <sup>2</sup>	200 cd/m <sup>2</sup>	
Touch Panel	4-wire system, Analogue		
Sound	Magnetic buzzer (85dB)		
Processor	ARM9 Core (32bit RISC), 454MHz		
Memory	Flash	128MB(Screen 64MB)	
	Operation RAM	128MB	
	Backup RAM	128KB	
Backup Type	Date/Time data, Logging/Alarm/Recipe data, non-volatile device		
Battery Capacity	Around 3 years (Upon operation at 25°C)		
Ethernet	-	1 channel, 10/100BASE-TX	
USB Port	1 channels, USB 2.0 host (mouse, keyboard, printer* and USB memory driver is available)		
	1 channel, USB 2.0 slave (for download and upload project file)		
RS-232C	1 channel		
RS-485	1 channel		
RS-422/485	1 channel, 422/485 Combination		
Multi-language	Up to 12 language simultaneously		
Animation	GIF format is available		
Recipe	available		
Data logging	available		
Script executor	available		
Certification	CE, UL(cUL), KC		
Protection	IP65		
Size (mm)	208.0 x 154.0 x 44.0		276.0 x 218.0 x 44.2
Panel Cut (mm)	192.0 x 138.0		260.0 x 202.0
Power	DC24V		
Power Consumption (W)	23.1	23.1	23.1
Weight (kg)	0.59	0.60	1.70

\*SEW00 printer only

## Dimensions

[Unit: mm]

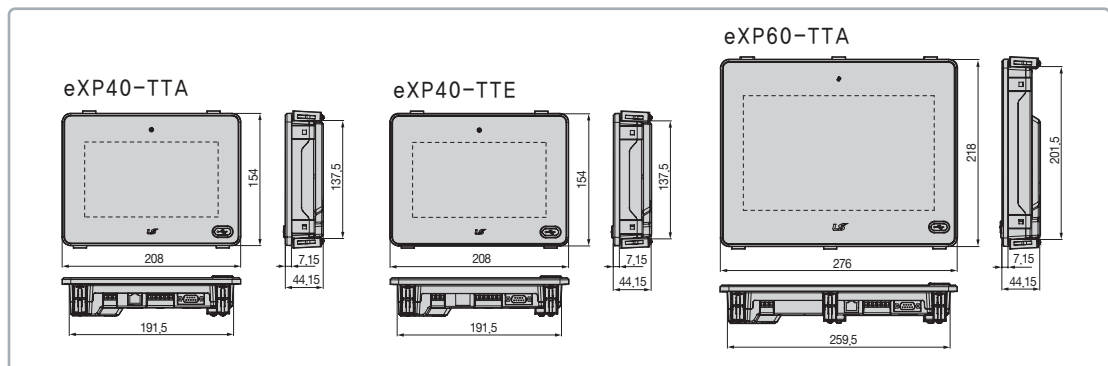

## LSIS Co., Ltd.